

P1 Petrol Lawn Mower

P4100P

P4600SP

P5100SPE

User Manual

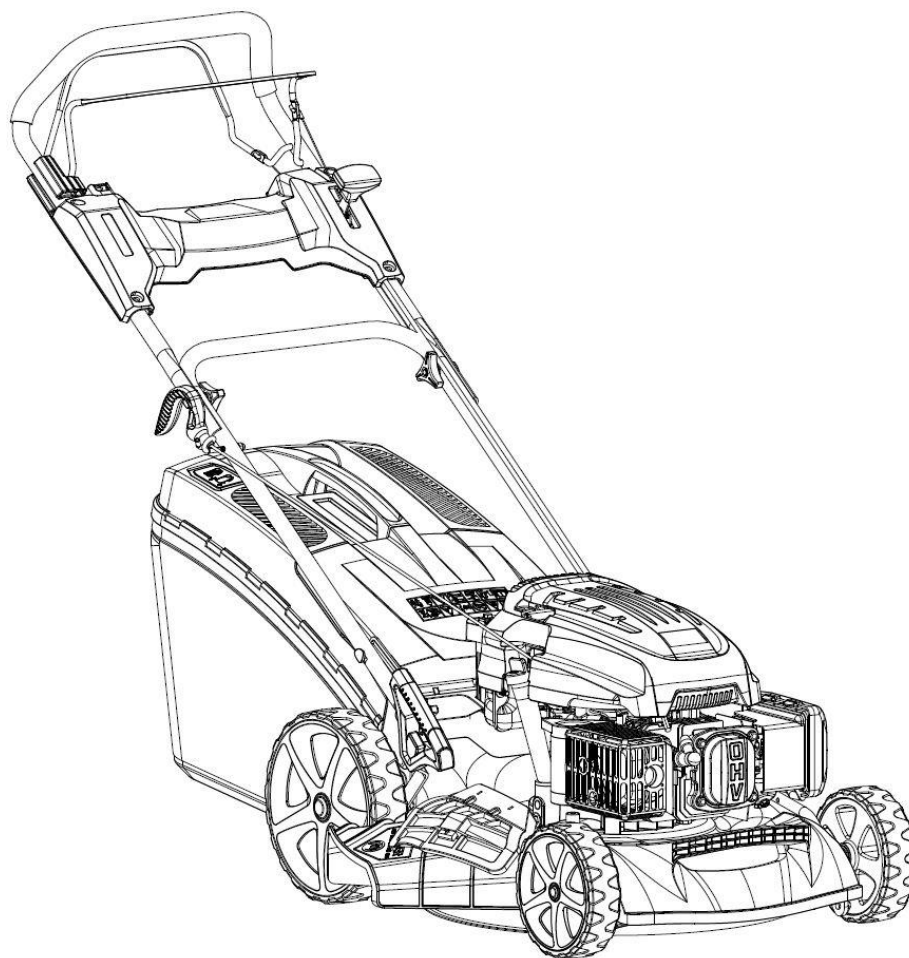

INDEX

	CONTENTS	PAGE NO.S
1	SAFETY	3-8
2	PART LOCATIONS	9
3	ASSEMBLY	10 – 13
4	STARTING PROCEDURE	14 - 16
6	STOPPING PROCEDURE	16
7	OPERATING INSTRUCTIONS	17 - 19
8	MAINTENANCE	20 – 30
9	STORAGE & WINTERISATION	30 – 31
10	TROUBLESHOOTING	32
11	SPECIFICATION	33
12	RECYCLING & PRODUCT DISPOSAL	34
13	DECLARATION OF CONFORMITY	35
14	CONTACT DETAILS	36
15	WARRANTY	36
16	MANUAL UPDATES	36

1. SAFETY

1.1 General Safety Notes.

- 1.2 The operator of the machine is responsible for, and has a duty of care in making sure that the machine is operated safely and in accordance with the instructions in this user manual. Keep the manual safe and pass it on if the machine is loaned or sold to another user.
- 1.3 Please note the following safety points.
- 1.4 The machine should never be left in a condition which would allow an untrained or unauthorised person/s to operate this machine.
- 1.5 All due care and diligence should be taken by the operator for the safety of and with regard to those around whilst using the machine.
- 1.6 Some or all of the following - warning signs, symbols and/or PPE pictograms may appear throughout this manual. You **MUST** adhere to their warnings. Failure to do so may result in personal injury to yourself or those around you.



DANGER

Indicates a hazard, which, if not avoided, could result in serious injury or death.



WARNING

Indicates a hazard, which, if not avoided, could result in serious injury.



CAUTION

Indicates a hazard which, if not avoided, might result in minor or moderate injury.



NOTE

Indicates a situation that could easily result in equipment damage.

READ and keep the manual safe and pass it on if the machine is loaned or sold to another user.

You **MUST** fully understand all instructions to ensure you use and operate the machine safely.

Appropriate Personal Protective Equipment (PPE), **MUST** be worn at all times when operating or repairing the machine.



HAND
PROTECTION
MUST BE WORN



EYE
PROTECTION
MUST BE WORN



PROTECTIVE
CLOTHING
MUST BE WORN



HEARING
PROTECTION
MUST BE WORN



FOOT
PROTECTION
MUST BE WORN



HEAD
PROTECTION
MUST BE WORN



RESPIRATOR
MUST BE WORN



FACE SHIELD
MUST BE WORN

1.10 Carbon Monoxide (where applicable).

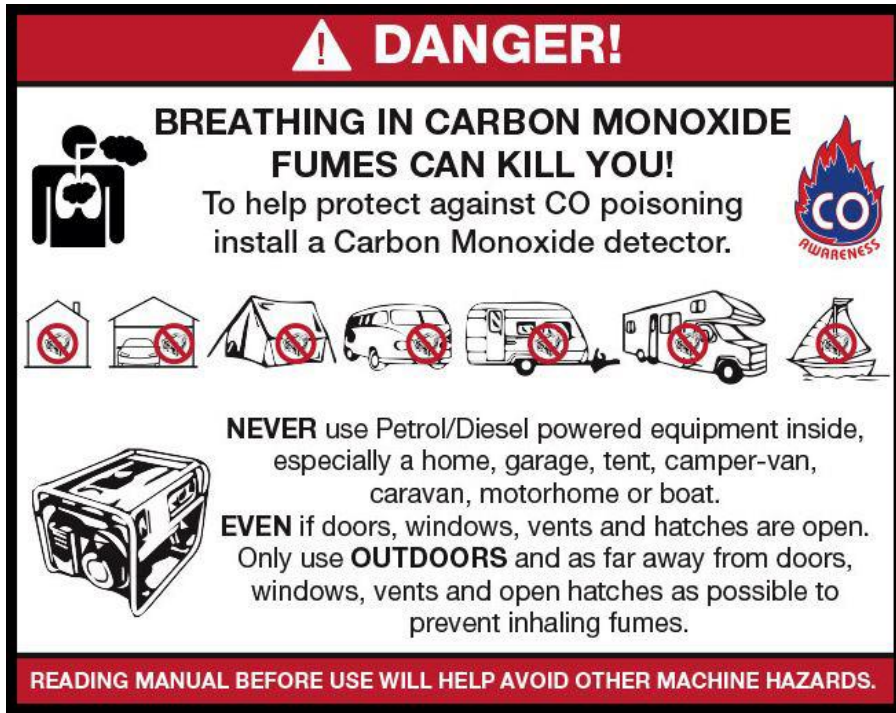

- 1.11 Carbon monoxide is a colourless and odourless gas. Inhaling this gas can cause death as well as serious long term health problems such as brain damage.
- 1.12 The symptoms of carbon monoxide poisoning can include but are not limited to the following;
Headaches, dizziness, nausea, breathlessness, collapsing or loss of consciousness.
- 1.13 Carbon monoxide poisoning symptoms are similar to flue, food poisoning, viral infections and simply tiredness. It is quite common for people to mistake this very dangerous poisoning for something else.
- 1.14 To avoid carbon monoxide poisoning **DO NOT** use Petrol/Diesel powered equipment inside any of the following; Home, garage, tent, camper van, mobile home, caravan or boat. This is not exhaustive and if you are in any doubt contact your dealer.
- 1.15 If you think you have or someone around you has been affected by carbon monoxide poisoning;
- 1.16 Get them fresh air immediately, by leaving the affected area or by opening doors and windows. If safe and practical to do so make sure that the machine is turned off. **DO NOT** enter a room you suspect of having carbon monoxide present – instead call the emergency services.
- 1.17 Contact a Doctor immediately or go to Hospital – let them know that you suspect carbon monoxide poisoning.
- 1.18 **DO NOT** use in an enclosed area or moving vehicle.

1.20 **General Fuel Safety (where applicable).**



CAUTION

ALL FUELS ARE FLAMABLE

1.21 Fire Hazard – keep fuel away from all sources of ignition for example heaters. Lamps, sparks from grinding or welding.



1.22 **DO NOT** carry out hot work on tanks that have contained fuel.

1.23 **ALWAYS** keep the work area tidy.

1.24 **ALWAYS** clean up spills promptly using absorbent granules and a lidded bin.

1.25 **ALWAYS** dispose of waste fuels correctly.

1.30 **Fueling/De-fueling (where applicable).**



CAUTION

ALL FUELS ARE FLAMABLE

1.31 **ALWAYS** fuel and defuel in a well ventilated area outside of buildings.

1.32 **ALWAYS** wear correct, suitable and fit for purpose Personal Protective Equipment (PPE), suggested items are but not limited to safety gloves, overalls.



1.33 When fueling/de-fueling **ALWAYS** avoid inhaling fumes.

1.34 When de-fueling **ALWAYS** use a proper fuel retriever.



1.35 **ALWAYS** carry fuel in the correct and clearly marked container.

1.40 **Electrical Safety (where applicable).**

1.41 Electricity can kill – **NEVER** work on **LIVE/ENERGISED** equipment.

1.42 Prior to carrying out any maintenance work you **MUST** identify electrical isolation methods and isolate all electrical supplies.

1.43 Prior to use and with all electrical supplies isolated, you **MUST** check all electrical cables, plugs and connectors for the following;

1.44 Are intact and have no signs of damage, to include but not limited to bare wires, chaffing, cuts and loose wiring.

1.45 If there are any signs of damage, the damaged item **MUST** be taken out of service until the damage has been repaired by an electrically competent person.

1.46 All trailing cables should be routed so as not to cause any kind of trip hazard.

1.47  **NEVER** work on or near electricity with wet hands, wet clothing and wet gloves.



1.50 **Batteries (where present).**

1.51 Batteries present a risk if they become damaged by the possible leaking of electrolyte. This electrolyte is an acid and can cause serious burn injuries. Care should be taken when working on or near them. **NOTE** the electrolyte may be in a liquid or gel form.

1.52 Should you come in to contact with electrolyte you should;

1.53 Remove all clothing contaminated with electrolyte. If you cannot remove then saturate them in water.

1.54 Get medical assistance as soon as possible. You must advise the medical staff of the type of acid.

1.55 Lead/acid battery = dilute sulphuric acid.

1.56 Nickel/cadmium = potassium hydroxide alkali electrolyte.

1.57 Use fresh running water to wash off excess electrolyte, continue this until medical assistance arrives. Make sure that you do not wash the electrolyte to another part of your body or face.

1.58 If electrolyte comes in to contact with Eyes the electrolyte needs to be immediately washed away with large amounts of water. Make sure that you do not wash the electrolyte to another part of your face or body.

1.59 Gasses from charging batteries are highly flammable and great care should be taken to charge in well ventilated areas.

1.59.1  There is an explosion risk if the battery terminals are short circuited, when connecting/disconnecting **ALWAYS** exercise great care so that the terminals or battery leads are **NOT** allowed to touch and cause a spark. **ALWAYS** use suitable insulated tools.



1.60 **Vibrations (where applicable).**

1.61 Prolonged use of hand held (operated) machines will cause the user to feel the effects of/from vibrations. These vibrations can lead to white finger (Raynaud's phenomenon) or carpal tunnel syndrome. This condition reduces the ability of the hand to feel and regulate temperature, causing numbness and heat sensations and may cause never damage and circulatory tissue death.

1.62 Not all factors that lead to white finger disease are known, but cold weather, smoking and other diseases that affect blood vessels and blood circulation as well as large and long-lasting impact of shocks are considered factors in the formation of white finger. Note the following to reduce the risk of white finger and carpal tunnel syndrome;

1.63 Wear gloves and keep your hands warm.

1.64 Take regular breaks.

1.65 All of the above precautions may help reduce the risk of white finger disease but not rule out the carpal tunnel syndrome. Long-term and regular users are therefore

recommended to observe the condition of your hands and fingers. Seek medical attention immediately if any of the above symptoms should occur.

1.70 Noise (where applicable).

1.71 The operating noise of the machine can damage your hearing. Wear hearing protection such as earplugs or ear defenders to protect your hearing. Long-term and regular users are advised to have hearing checked regularly. Be especially vigilant and cautious when hearing ear protection because your ability to hear alarm warnings will be reduced.

1.72 Noise emissions for this equipment is unavoidable. Carry out noisy work at approved times and for certain periods. Limit the working time to a minimum. For your personal protection and protection of people working nearby it is also advisable for them to wear hearing protection.

1.73 See Certificate of Conformity section for Outdoor Noise declaration of conformity.



MACHINE SPECIFIC SAFETY

1.80 General Machine Safety.

1.81 Read the owner's manual carefully to understand how to operate this machine properly.

1.82 You should **NEVER** use the machine when;

1.83 Wearing loose clothing, barefoot or sandals.

1.84 Under the influence of drink or drugs or as a result of having taken medication for cold or flu, or any other times when a possibility exists that your judgement might be impaired or that you might not be able to operate the machine properly and in a safe manner.

1.85 Suffering from exhaustion or lack of sleep.

1.86 When the ground is slippery or when other conditions exist which might make it not possible to maintain a steady posture.

1.87 At night, at times of heavy fog, or at any other times when your field of vision might be limited and it would be difficult to gain a clear view of the area.

1.88 During rain storms, lightning storms, at times of strong or gale force winds, or at any other times when the weather conditions might make it unsafe to use this product.

1.89 **NEVER** run the engine indoors. The exhaust gasses contain harmful carbon monoxide.

1.90 When using this machine for the first time and before actual work, you **MUST** learn how to handle the machine from an experienced or skilled person.

1.91 Limit the amount of time using the machine continuously to somewhere around 10 minutes per session and take 10 to 20 minutes of rest between sessions. Also try to keep the total amount of work in a single day limited to 2 hours or less.

- 1.92 **NEVER** allow children or anyone unable to fully understand the directions given in this manual to operate this product.
- 1.93 Make sure you keep this manual handy so you may refer to it whenever questions arise and ensure you pass this manual on if the machine is loaned or sold.
- 1.94 Correct Personal Protective Equipment (PPE) **MUST** be worn at all times when operating or repairing this machine. This should include but is not limited to;



- 1.95 Do not use this machine inside a confined space such as but not limited to a vehicle, house, garage, container, boat or building. Only use outside in a well ventilate area.
- 1.96 For air cooling a minimum of 1m is required all around the machine. Maximum ambient temperature 40 degrees Celsius.
- 1.97 Fire risk- Fuel can expand and overflow in a hot environment or moving vehicle. Explosion risk- LPG/ Petrol can leak and the vapour is heavier than air. Never store in confined spaces especially in a boat where the vapour/has will accumulate in the hull and create a high risk of explosion.
- 1.98 Carbon monoxide poisoning risk- Never run an engine in a confined space or poorly ventilated area. Keep machine away from windows to prevent fumes entering the internal space. Carbon monoxide is produced by the engine and contained in the exhaust fumes. You cannot see it or smell it and it can kill you in minutes.
- 1.99 Never use inside a confined space with an exhaust extension. If the exhaust extension fails the escaping exhaust gases could kill you.

2. PART LOCATIONS

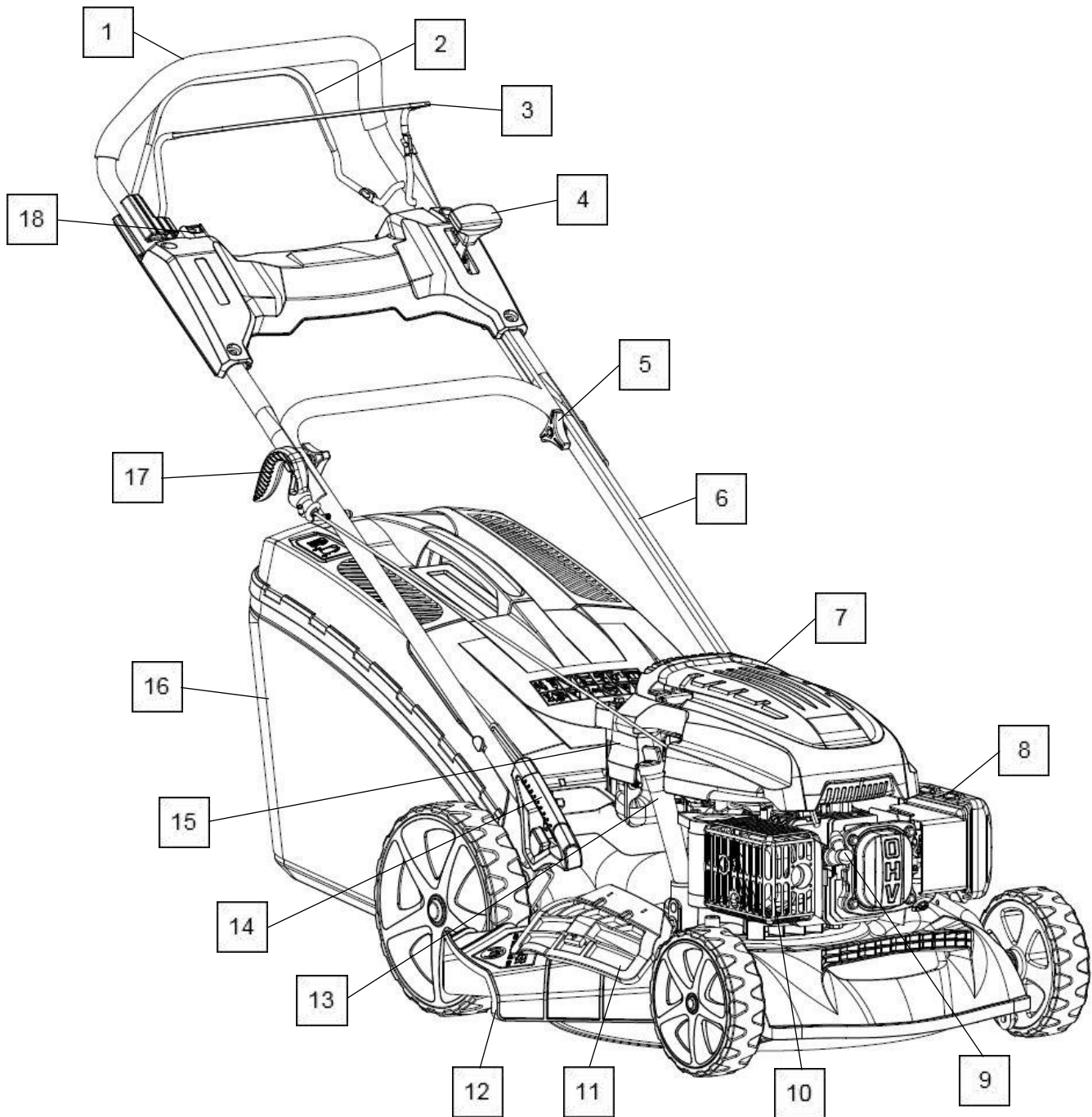

1	Upper Handle	10	Exhaust
2	Drive Lever*	11	Side Discharge Cover*
3	Operator Presence Control Lever	12	Side Discharge Chute*
4	Throttle Lever*	13	Oil Filler/Dipstick
5	Handle Quick Release	14	Wheel Height Adjustment Lever
6	Lower Handle	15	Battery*
7	Fuel Filler Cap	16	Grass Collector
8	Air Filter	17	Recoil Start Handle
9	Spark Plug	18	Electric Start Button*

* P5100SPE Only

3. ASSEMBLY



WARNING

This guide is meant to serve as a quick reference for operating your P1 lawn mower.

We advise reading the manual in full before operation.



NOTE

This lawnmower is shipped without oil or petrol.

You **MUST** ensure the correct oil and fuel is used **BEFORE** use

Oil: Semi-Synthetic SAE 15W40 Engine Oil.

Oil Capacity P4100P: 600ml

Oil Capacity P4600SP: 600ml

Oil Capacity P5100SPE: 600ml

Fuel: Unleaded Petrol

Fuel Capacity P4100P: 800ml

Fuel Capacity P4600SP: 1000ml

Fuel Capacity P5100SPE: 1000ml

- 2.0 Attach the lower handle to the lawnmower deck.
- 2.1 **NOTE:** You can select 2 different handle heights, select the most comfortable and secure tightly.
- 2.2 Attach the upper handle to the lower handle and slowly pull the recoil start handle up to the retaining loop on the handle bars.

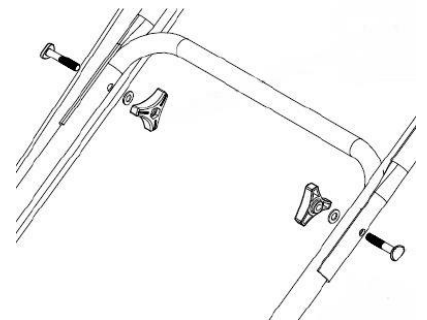
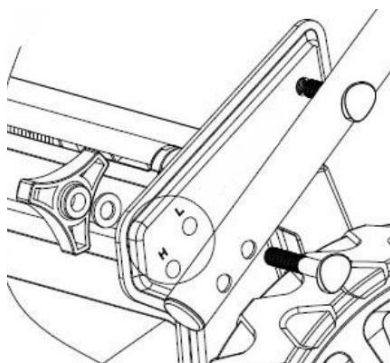
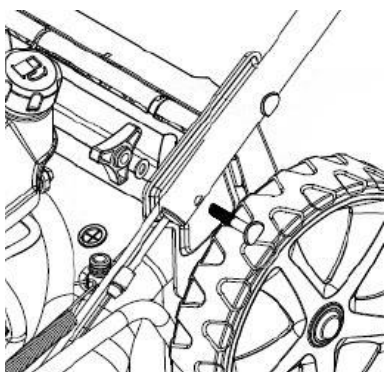

- 2.3 To attach the cables, gently push the handle free from its locating hole on the main upper handle.
- 2.4 Insert the end of the cable in to the locating hole on the lever.
- 2.5 Follow the curve of the cable until it lies flat in the handle.
- 2.6 Refit the lever back into its location hole and check the cable isn't snagged on any other part of the lawn mower.

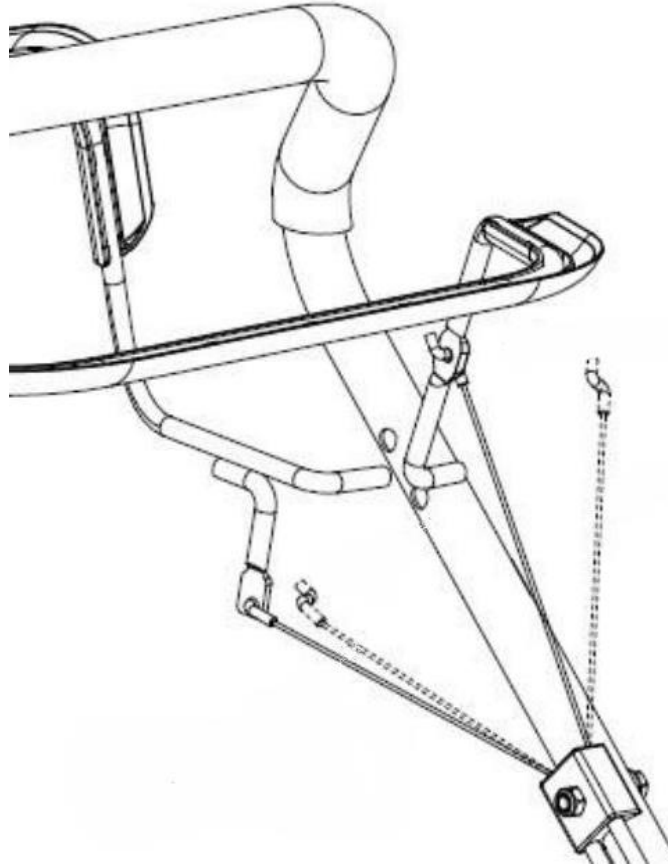

- 2.7 **P5100SPE ONLY:** Attach the centre electric start panel to the mounting points on the upper handle.

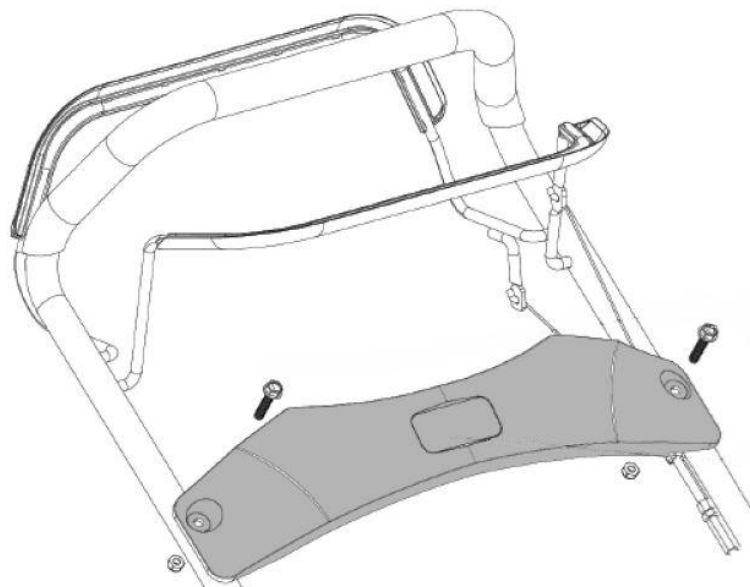

- 2.8 Lift the rear discharge flap and remove the mulching plug, if installed.
- 2.9 Hook the grass collector over the mounting bar and lower the rear discharge flap until it rests on top of the grass collector.

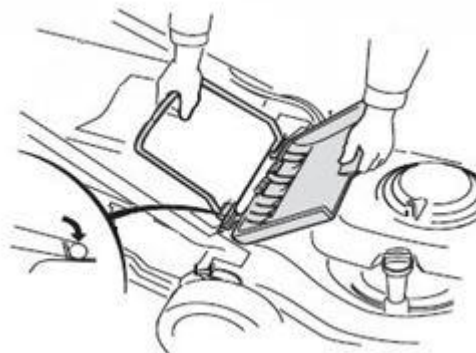

ADDING OIL

- 2.10 Place the lawn mower on a flat level surface.
- 2.11 Unscrew and remove the dipstick.
- 2.12 Slowly fill with oil to the upper limit mark on the dipstick.
Stop occasionally to check the level.
DO NOT overfill.

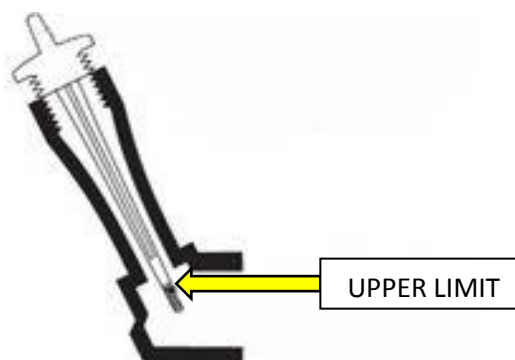
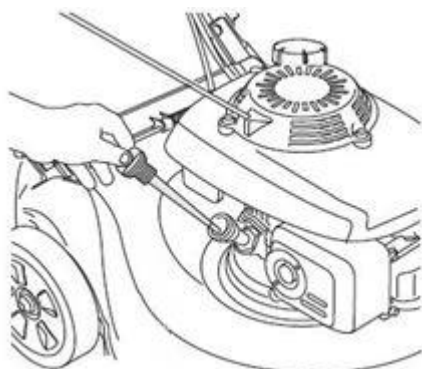

- 3.13 If you do overfill, you can remove some oil by gently tilting the machine on its side and pouring the excess oil into a suitable container.

ADDING FUEL



CAUTION

ALL FUELS ARE HIGHLY FLAMMABLE

ALWAYS fuel and defuel in a well ventilated area outside of buildings and away from any possible sources of ignition.

ALWAYS wear correct, suitable and fit for purpose Personal Protective Equipment (PPE). Suggested items are but not limited to, safety gloves, eye protection and overalls.

- 3.14 Place the lawn mower on a flat level surface.
- 3.15 Remove the fuel filler cap (2) and slowly fill with unleaded petrol.
- 3.16 **DO NOT** fill the tank right to the top but leave a 25mm gap between the top of the fuel tank and the fuel filler cap.
- 3.17 Once full, refit the fuel filler cap securely.

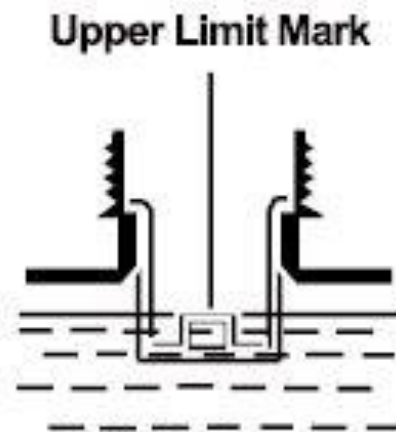
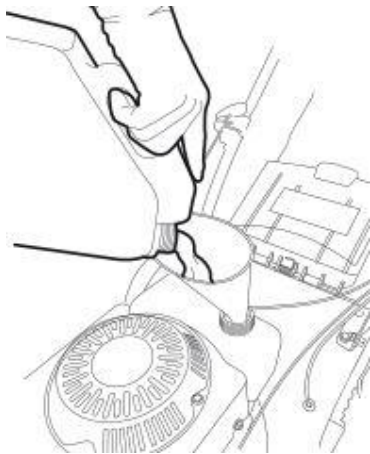

CHARGING THE BATTERY P5100SPE ONLY

- 3.18 The battery must be charged for 5 hours before use.
- 3.19 Connect the charger to the charging port on the battery.
- 3.20 Plug the charger in to the mains and turn on.

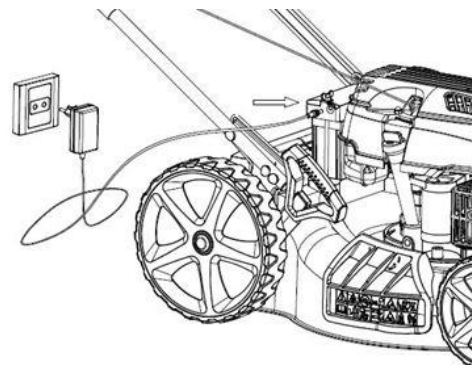
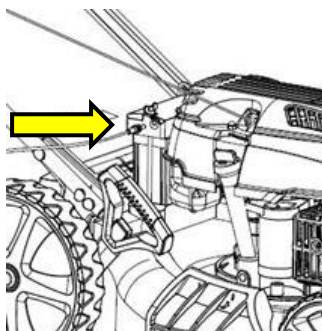

4. STARTING PROCEDURE



NOTE

This lawnmower is shipped without oil or petrol.
You **MUST** ensure the correct oil and fuel is used **BEFORE** use.

Oil: Semi-Synthetic SAE 15W40 Engine Oil.

Oil Capacity P4100P: 600ml

Oil Capacity P4600SP: 600ml

Oil Capacity P5100SPE: 600ml

Fuel: Unleaded Petrol

Fuel Capacity P4100P: 800ml

Fuel Capacity P4600SP: 1000ml

Fuel Capacity P5100SPE: 1000ml

COLD RECOIL START – ALL MODELS

- 4.0 Make sure the blade is free of long grass and the cutting height is set to maximum.
- 4.1 **P4100P & P4600SP ONLY:** Pump the primer bulb 5 times.
- 4.2 **P5100SPE ONLY:** Push the throttle lever forward to the choke position.

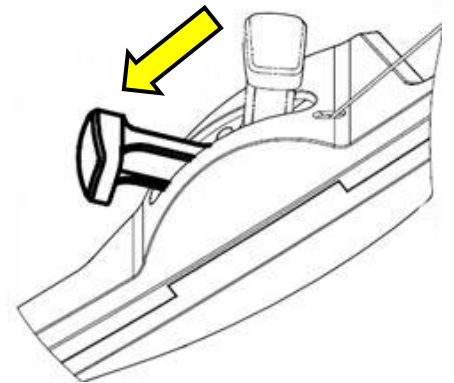
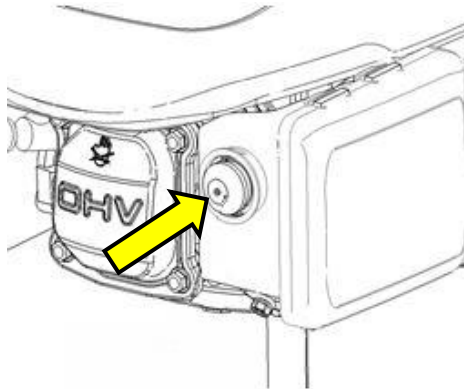
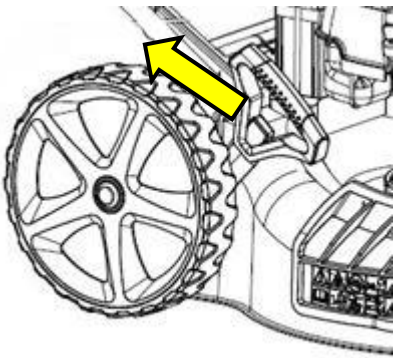

- 4.3 Pull the Operator Presence Control (OPC) lever (2) towards the main handle.

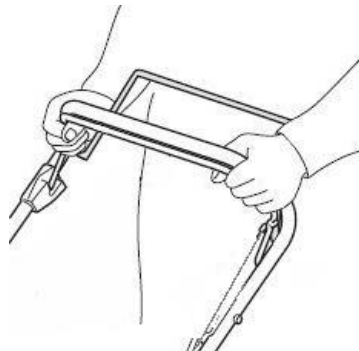

- 4.4 Gently pull the recoil start handle until you feel resistance, then pull swiftly until the lawn mower starts.
- 4.5 **P5100SPE ONLY:** Allow to run for 15 seconds, then slowly move the choke lever back to the run position.

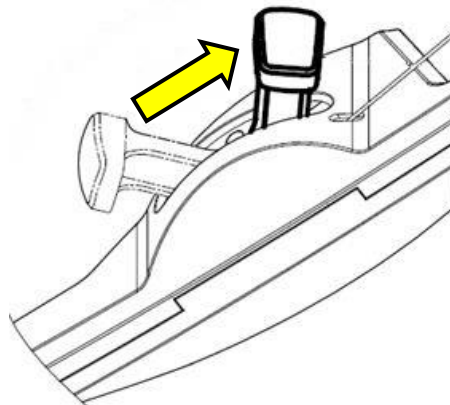

COLD ELECTRIC START – P5100SPE ONLY

- 4.6 Charge the battery for 5 hours before first use and then after every 10 uses on average (1).
- 4.7 Make sure the blade is free of long grass and the cutting height is set to maximum (2).
- 4.8 Push the throttle lever forward to the choke position (3).

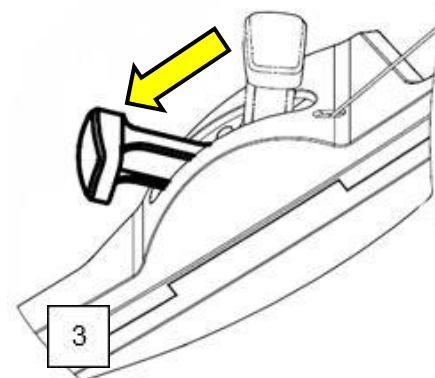
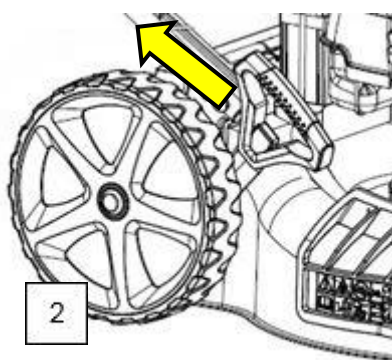
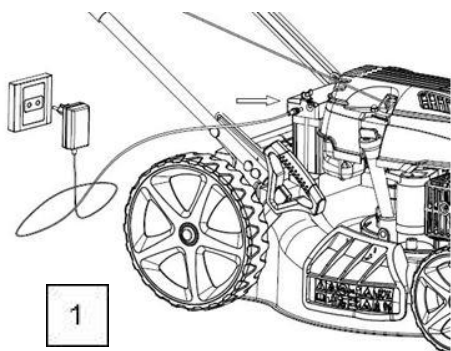

- 4.9 Pull the Operator Presence Control (OPC) lever towards the main handle.
- 4.10 Push the start button for 3 seconds, repeat until the engine starts.
- 4.11 Allow to run for 15 seconds, then slowly move the choke lever back to the run position.

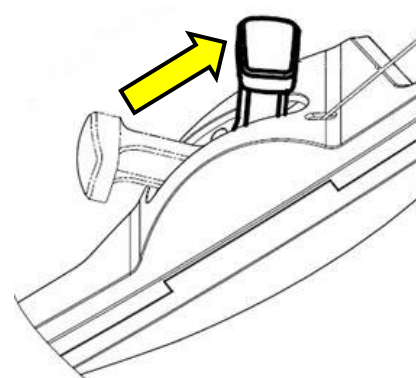
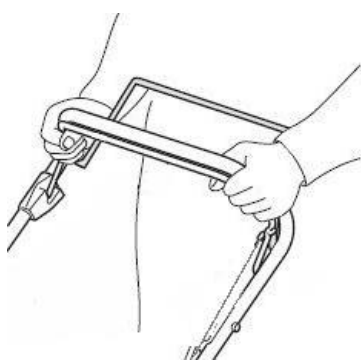

WARM START – ALL MODELS

- 4.12 Follow the procedure for a cold start.
- 4.13 **P5100P & P4600SP:** Do not use the primer bulb to prime the engine.
- 4.14 **P5100SPE:** Leave the throttle in the run position.

5. STOPPING PROCEDURE



CAUTION

The engine and exhaust will remain hot for a while after use. Ensure the engine and exhaust have cooled before carrying out any maintenance or storing the machine.

- 5.0 Before stopping the machine, you must allow the engine to idle under no load for 30 seconds.
- 5.1 Release the Operator Presence Control (OPC) lever (1) and the engine will stop.

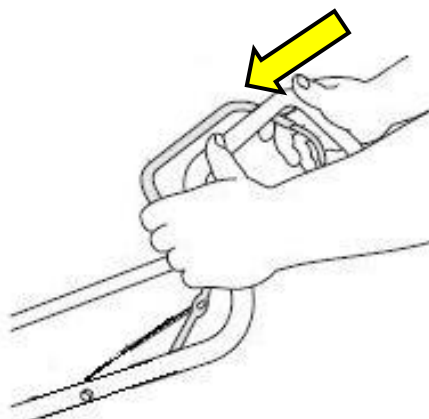

6. OPERATING INSTRUCTIONS



NOTE

Not all features are available on every lawn mower.
Images may vary depending on model.

- 6.0 Always use the lawn mower with the grass catcher or rear deflector in position.
- 6.1 Stop the engine before emptying the grass catcher or before you change the cutting height.
- 6.2 Never put your hands or feet near the mower when running.
- 6.3 Before mowing, remove all foreign objects from the lawn which may cause injury or damage.
- 6.4 Keep children, people and pets at a safe distance (at least 20m) when the lawn mower is in use.
- 6.5 Always wear appropriate Personal Protective Equipment (PPE) when using this machine.
Suggested PPE but not limited to: Sturdy Footwear, Work Gloves, Long Trousers, Hearing Protection and Safety Glasses.
- 6.6 Never work barefoot or in sandals.
- 6.7 Do not operate the engine in a confined space where dangerous carbon monoxide fumes can collect.
- 6.8 Avoid operating the equipment in wet grass.
- 6.9 Only use this machine in daylight.
- 6.10 Always be sure of your footing on slopes, walk and never run.
- 6.10 For wheeled rotary machines, mow across the face of slopes, never up and down.
- 6.11 Exercise extreme caution when changing direction on slopes.
- 6.12 Use extreme caution when reversing or pulling the lawn mower towards you in case you slip and your feet go underneath the machine.
- 6.13 Stop the engine and allow the blade to come to a complete stop if the lawn mower has to be tilted for transportation when crossing surfaces.
- 6.14 Never operate the lawn mower with defective guards or without safety devices for example, deflectors, safety guards and/or grass catchers in place.
- 6.15 Do not change the engine governor settings.
If the engine speed is too high it will cause excessive wear.
If the engine speed is too low it will not cut or pick up the grass effectively.
- 6.16 Engage all blade and drive clutches before starting the engine.
- 6.17 Start the engine carefully, according to the instructions and with feet well away from any rotating parts.
- 6.18 Do not tilt the lawn mower when starting the engine.

- 6.19 Do not put hands or feet near or under any rotating parts.
- 6.20 Never pick up or carry a lawn mower while the engine is running.
- 6.21 Before attempting to clear blockages, check, clean, refuel or after striking a foreign object – Stop the engine, allow to cool and disconnect the spark plug cap. Make sure the blades have come to a complete stop.

GRASS COLLECTION MOWING

- 6.22 Lift the rear discharge flap.
- 6.23 Remove the mulching plug if your model has the mulching option.
- 6.24 Hook the grass catcher over the mounting points and lower the rear discharge flap down onto the grass collector.

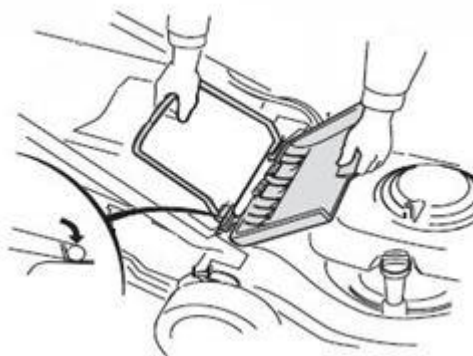

MULCHING MOWING

- 6.25 Lift the rear discharge flap and remove the grass collector.
- 6.26 Insert the mulching plug into the rear discharge chute until it clicks into place.
- 6.27 Lower the rear discharge flap.

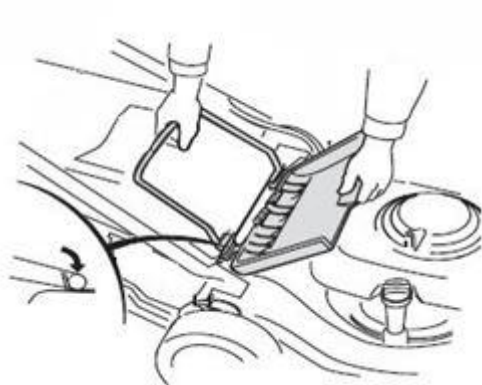

REAR DISCHARGE

- 6.28 Lift the rear discharge flap and remove the grass collector.
- 6.29 Insert the 2 plastic tabs into the slot underneath the rear discharge flap.
- 6.30 Lower the rear discharge flap until it rests on the 2 plastic tabs.

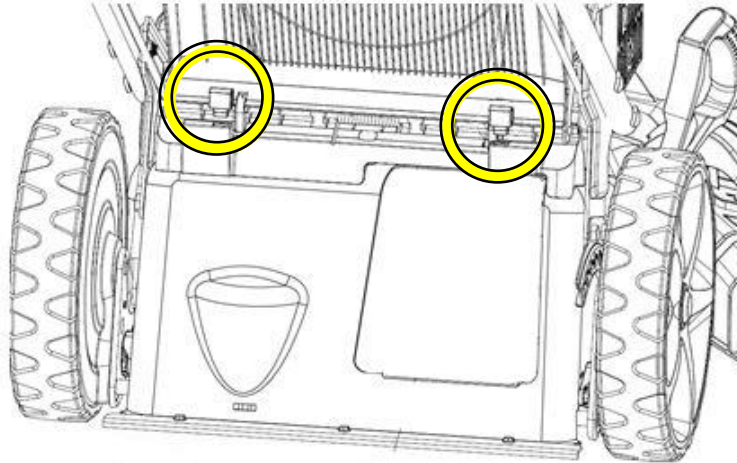

SIDE DISCHARGE MOWING – P5100SPE ONLY

- 6.31 Lift the rear discharge flap and remove the grass collector.
- 6.32 Lift the locking tab on the side discharge flap.
- 6.33 Lift the side discharge flap to show the two discharge chute tabs.
- 6.34 Hook the side discharge chute over the two tabs.
- 6.35 Lower the side discharge flap so it rests on the top of the side discharge chute.

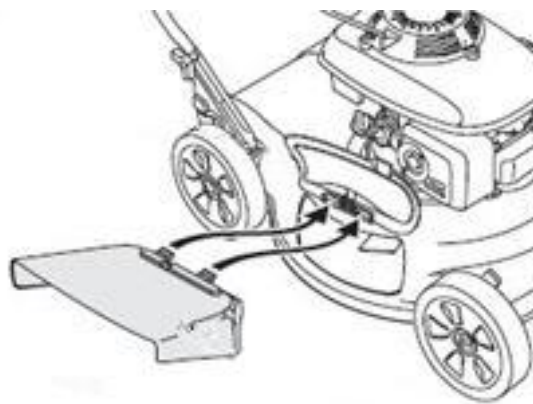

7. MAINTENANCE



WARNING

ALWAYS stop the engine, unplug the spark plug HT lead and allow the engine to cool before carrying out any repairs, maintenance, refuelling or removal of blockages.

NEVER touch any rotating part of the lawn mower.

ALWAYS wear appropriate Personal Protective Equipment (PPE) when using or maintaining this machine.



HAND
PROTECTION
MUST BE WORN



EYE
PROTECTION
MUST BE WORN



PROTECTIVE
CLOTHING
MUST BE WORN



HEARING
PROTECTION
MUST BE WORN



FOOT
PROTECTION
MUST BE WORN



HEAD
PROTECTION
MUST BE WORN



RESPIRATOR
MUST BE WORN



FACE SHIELD
MUST BE WORN

ALWAYS fuel and defuel in a well ventilated area with the engine off and allowed to cool.

NEVER start or run the machine indoors or in an enclosed space. This machine produces carbon monoxide which can kill.

! DANGER!



BREATHING IN CARBON MONOXIDE FUMES CAN KILL YOU!

To help protect against CO poisoning install a Carbon Monoxide detector.







NEVER use Petrol/Diesel powered equipment inside, especially a home, garage, tent, camper-van, caravan, motorhome or boat.

EVEN if doors, windows, vents and hatches are open. Only use **OUTDOORS** and as far away from doors, windows, vents and open hatches as possible to prevent inhaling fumes.

READING MANUAL BEFORE USE WILL HELP AVOID OTHER MACHINE HAZARDS.

OPC CABLE ADJUSTMENT



NOTE

Before use you **MUST** check and if necessary, adjust the Operator Presence Control (OPC) cable.

If the cable is too loose, the lawn mower will not start.

There should be no more than 10mm free play in the OPC cable.

To check, start to pull the OPC lever towards the main handle.

The OPC cable should start to move within 10mm of pulling the handle.

- 3.27 If adjustment is required, trace the OPC cable down from the handle to the engine of the lawn mower, until you reach the OPC cable adjuster (1).
- 3.28 Undo the lock nut (2) and wind it forwards (3).

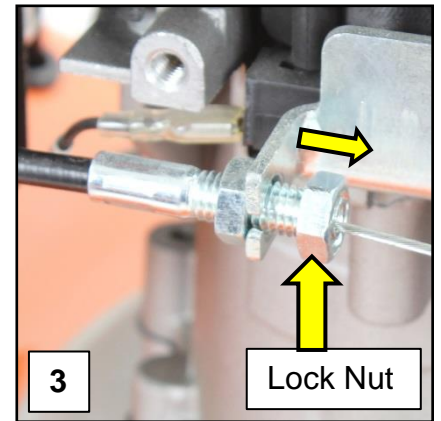
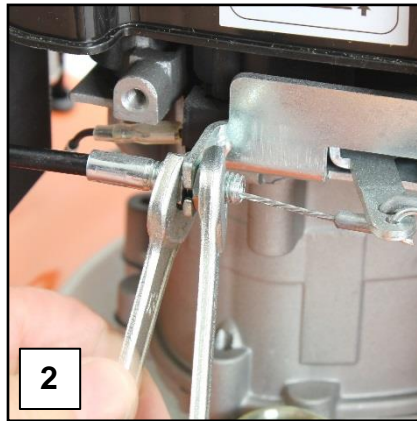
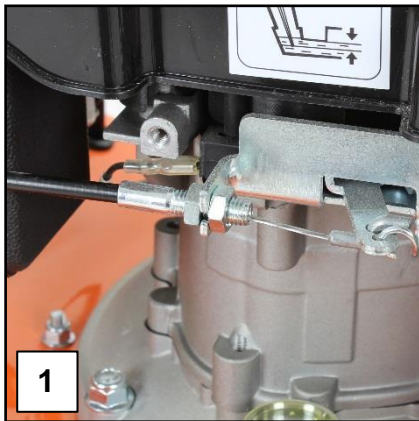

- 3.29 Wind the adjuster nut towards the lock nut. As you adjust, keep checking the tension on the OPC cable until the desired tension is reached.
- 3.30 Tighten the lock nut back towards the adjuster nut (2) and then attempt to start the lawn mower.
- 3.31 If the lawn mower starts, tighten both nut securely. If not, repeat the process until the lawn mower will start.

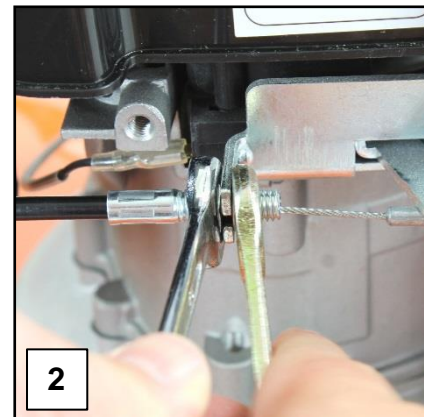
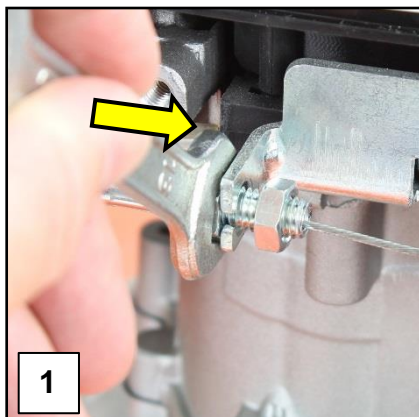

NOTE

There should be no more than 10mm free play in the drive cable for a self-propelled lawn mower, otherwise the self-propelled drive will fail to work correctly.

To check, start to pull the drive lever towards the main handle.
The drive cable should start to move within 10mm of pulling the handle.

- 3.32 There should be no more that 10mm free play in the drive cable, when you check the cable for tension.
- 3.33 If adjustment is required, trace the drive cable down towards the gearbox of the lawn mower, until you reach to drive cable adjuster (1).
- 3.34 Undo the lock nut and wind away from the adjuster nut (2).

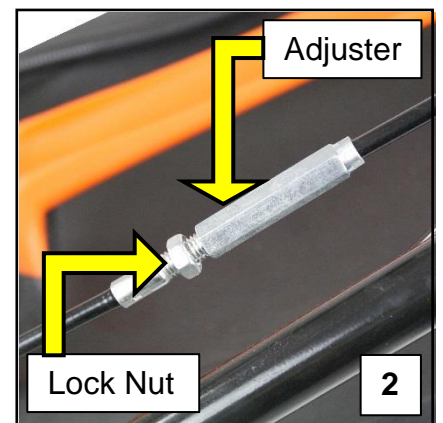

- 3.34 Wind the adjuster nut towards the main handlebar.
As you adjust, keep checking the tension on the drive cable until the desired tension is reached (1).
- 3.35 Tighten the lock nut finger tight, back towards the adjuster nut (2) and check for drive on the lawn mower.
Once drive is restored, tighten the lock nut securely.

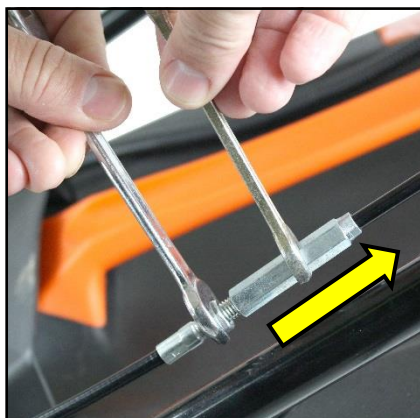



NOTE

Oil Type All Models: Semi Synthetic SAE15W40 Engine Oil

Oil Capacity P4100P: 400ml

Oil Capacity P4600SP & P5100SPE: 600ml

- 7.0 The oil must be checked before every use.
- 7.1 We recommend doing an oil service at least once a year, more frequently during periods of heavy use.
- 7.2 Disconnect the spark plug HT lead cap and with the engine oil warm, not hot, remove the dipstick.
- 7.3 Gently tilt the machine to allow the oil to drain from the dipstick port into a suitable container.
- 7.4 Refill slowly with approx. 600ml of fresh Semi-Synthetic SAE 15W40 engine oil to the upper level mark on the dipstick.
- 7.5 Stop occasionally to check the oil level.

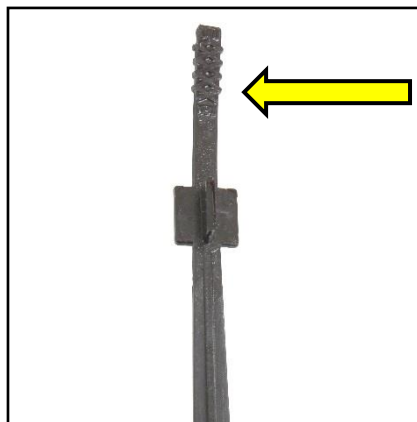

- 7.6 Do not overfill.
- 7.7 If you do overfill, gently tilt the machine and allow the excess oil to drain from the dipstick port, in to a suitable container.
- 7.8 Refit the dipstick securely.

SPARK PLUG



NOTE

Recommended Spark Plug P4100P: NGK BPR6ES or equivalent

Recommended Spark Plug P4600SP & P5100SPE: NGK BP6ES or equivalent

Spark Plug Gap All Models: 0.7 ~ 0.8mm (0.28" ~ 0.32")

- 7.9 We recommend checking the spark plug after every 25 hours of use and replacing once a year.
- 7.10 Allow the engine to completely cool.
- 7.11 Remove the spark plug HT lead cap (1) to expose the spark plug (2).
- 7.12 Using a spark plug spanner (3), remove the spark plug (4).



- 7.13 Inspect and clean the spark plug electrode, making sure there is no damage to the insulator or electrode.
- 7.14 If there is any damage or wear to the spark plug, replace immediately.
- 7.15 Using a feeler gauge, check the spark plug gap. The plug gap should be 0.70mm to 0.80mm, carefully adjust the plug gap by bending the side electrode.

0.70mm – 0.80mm



- 7.16 Refit the cleaned and adjusted spark plug by hand to avoid cross threading.
- 7.17 Once the spark plug seats, tighten with the spark plug spanner **DO NOT** overtighten.
- 7.18 Replace the spark plug HT lead cap.

AIR FILTER



CAUTION

Never operate the lawn mower without an air filter installed. It can cause damage to the engine which will not be covered by the warranty.

When using the lawn mower in very dusty areas, you must clean or replace the air filter more frequently.

- 7.19 We recommend checking the air after every 25 hours of use and replacing once a year.
- 7.20 Allow the engine to completely cool and disconnect the spark plug HT lead cap.
- 7.21 Push down the latch tabs on the side of the air filter box (1) to reveal the air filter (2).
- 7.22 Remove the air filter (3) and ensure no dirt or debris can enter the carburetor chamber.

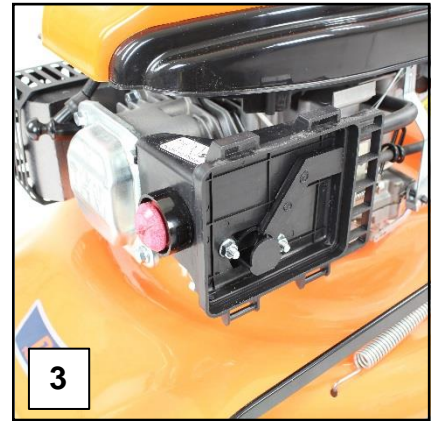
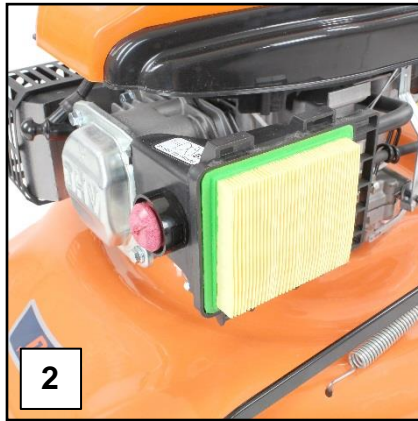
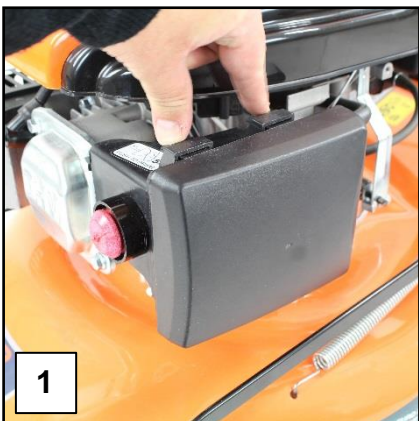

- 7.22 If a paper air filter is fitted, inspect and replace if necessary. Otherwise gently blow compressed air, not exceeding 30psi, through the filter from the reverse side to remove the majority of dirt and debris and reinstall.

- 7.33 If a foam filter is installed, inspect and replace if necessary.
Otherwise, wash the air filter in a warm soap solution, rinse and allow to dry.
- 7.34 Once dry, soak the foam filter in fresh engine oil and allow the excess to drain off.
- 7.35 Reinstall the air filter and close the air filter cover.

LAWN MOWER BLADE



CAUTION

ALWAYS handle the lawn mower blade wearing thick gloves suitable for purpose. Lawn mower blades can be sharp and cause personal injury if handled incorrectly.

- 7.36 We recommend inspecting the blade for wear or damage every 25 hours of work.
- 7.37 To inspect or remove the blade it is advisable to drain all the fluids from the mower and disconnect the spark plug HT lead cap before inspecting.
- 7.38 Turn the lawn mower on to its side (1) making sure the side the air filter is installed on, is facing up.
- 7.39 Using suitable gloves, firmly hold the blade and undo the centre bolt in an anti-clockwise direction (2).
NOTE: this may be stiff as the bolt needs to be installed tightly.
- 7.40 Remove the blade (3).



- 7.41 With the blade removed, inspect for straightness, damage and wear. Replace the blade if it shows signs of any of these, otherwise have the blade sharpened and balanced.
- 7.42 Reinstall the blade securely by reversing the procedure above.

DRIVE BELT



CAUTION

ALWAYS handle the lawn mower blade wearing thick gloves suitable for purpose. Lawn mower blades can be sharp and cause personal injury if handled incorrectly.

- 7.43 We recommend inspecting the drive belt as part of an annual inspection. More frequently during periods of heavy use.
- 7.44 If drive has been lost, check the cable adjustment first as set out in sections 3.32 to 3.35 before inspecting the belt.
- 7.45
- 7.46 Remove the lawn mower blade as set out in sections 7.37 to 7.42.
- 7.47 Remove the drive coupling and spacer (1 & 2).
Be careful not to lose the keyway attached to the drive shaft (3).

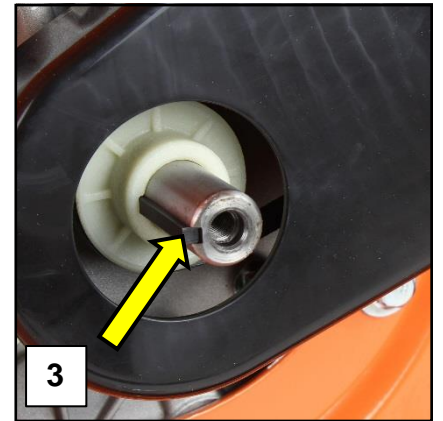
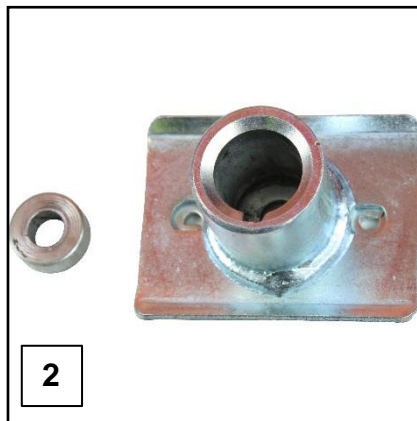

- 7.48 Remove the plastic drive belt guard by undoing the 2 bolts and screw holding it in place (1) to expose the drive belt (2).
- 7.49 Inspect the belt for wear or damage and check tension (3).
There should be no more than 10mm free play when gently checking tension.

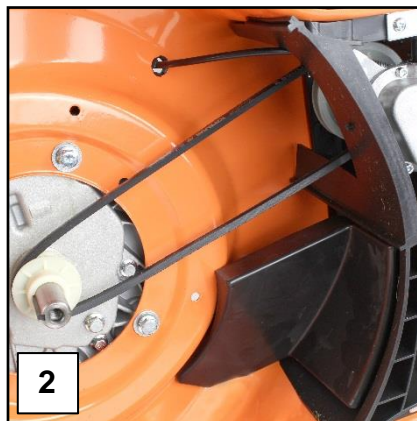
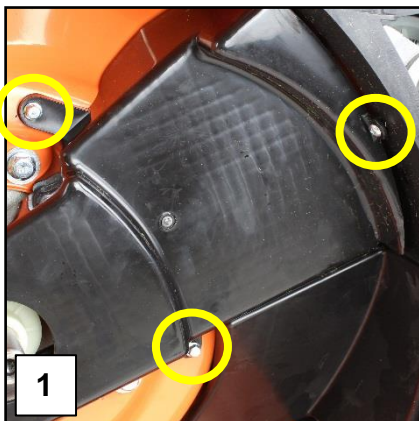

- 7.50 If the belt is damaged or worn, replace immediately.
- 7.51 Loosen the tension on the drive belt by undoing the lock nut on the drive cable (1 & 2).
- 7.52 Wind the lock nut and the adjuster nut all the way to the bottom to allow enough free play to be able to remove the drive belt (3).

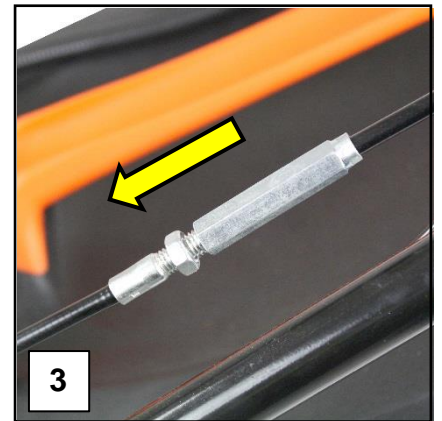
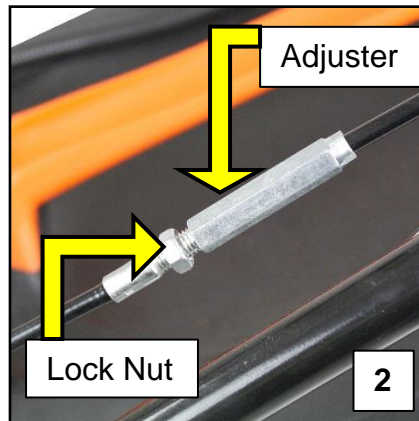
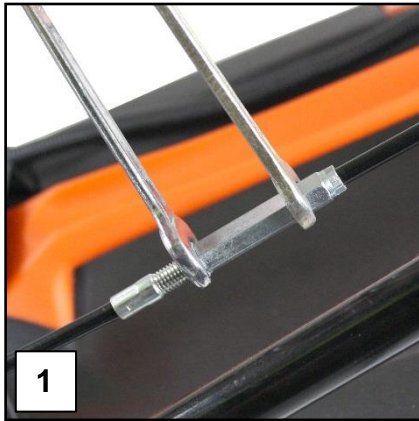

- 7.53 Unhook the belt from the main drive pulley (1).
- 7.54 Unhook the belt from the rear pulley (2).
- 7.55 The belt should now be free to remove completely (3).

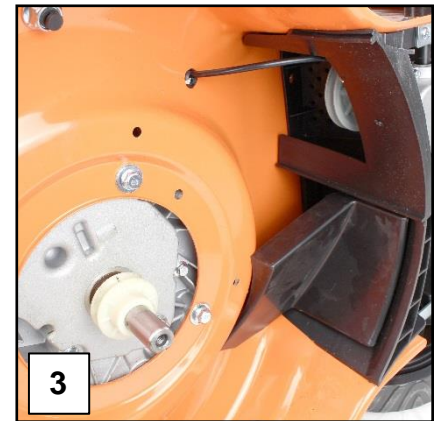
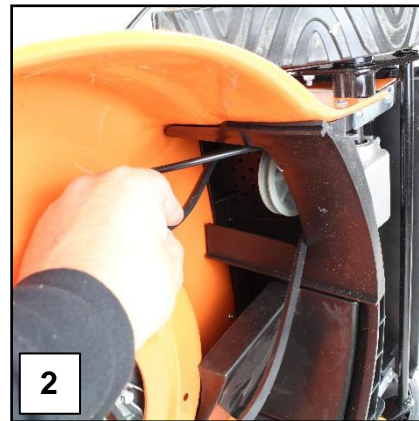

- 7.56 To reinstall, reverse the procedure above.

CARBURETOR



WARNING

ALL FUELS ARE HIGHLY FLAMMABLE

ALWAYS fuel and defuel in a well ventilated area outside of buildings and away from any possible sources of ignition.

- 7.57 To drain fuel from the float bowl of the carburetor, drain all the fuel from the fuel tank.
- 7.58 Locate the carburetor float bowl at the front of the lawn mower (1).
- 7.59 Place a suitable container underneath the float bowl and unscrew the drain screw located on the angled side of the float bowl (2).
- 7.60 Take care not to lose the washer on the drain screw.
- 7.61 Allow all the fuel to drain before reinstalling the drain plug screw.

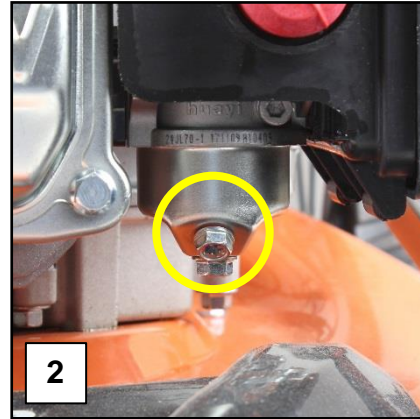
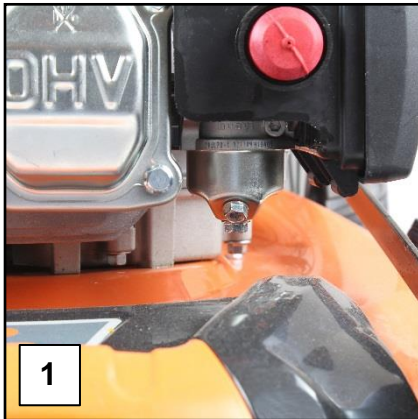

CLEANING



NOTE

DO NOT use a pressure washer or hose pipe to clean your lawn mower (unless fitted with hose pipe attachment).

Water could damage internal and external components of the lawn mower and engine and cause catastrophic failure that will not be covered by the warranty.

It is recommended to clean your lawn mower after every use to help prolong the life of the lawn mower and ensure it works efficiently.

- 7.62 Allow the lawn mower to cool completely and remove the spark plug HT lead cap.
- 7.63 Remove any clippings or debris from the top of the lawn mower deck.

- 7.64 Check the cooling fins on the engine are free from dirt and debris. Use a soft brush to clean if required.
- 7.65 Lightly grease any moving cables or parts using a silicone based spray grease.
- 7.66 Drain all the fuel and oil from the lawn mower.
- 7.67 If your lawn mower is fitted with a deck mounted hose port, connect a hose pipe to the port and rinse the underside of the lawn mower deck.
- 7.68 Remove the grass bag and place the lawn mower on its side ensuring the air filter is facing up.
- 7.69 Wearing suitable gloves and using a damp cloth, wipe away any grass clipping from the underside of the lawn mower deck and the lawn mower blade.
- 7.70 For more stubborn or dried on clippings use a hand trowel or similar.
- 7.71 Using a damp (not wet) cloth, wipe the underside of the lawn mower deck and blade.
- 7.72 Wipe over with a dry cloth.

8. STORAGE & WINTERISATION



NOTE

If storing the lawn mower for a period of 30 days or more, you must follow proper storage and winterisation guidelines to avoid any possible issues with your lawn mower.

Incorrect storage can lead to possible fueling or engine issues that will not be covered by the warranty.

- 8.0 Drain all the fuel from the fuel tank and then run the lawn mower until it has completely run out of fuel to clear the remaining fuel from the fuel lines and carburetor.
- 8.1 Drain the oil from the engine as set out in section 7.1 to 7.3.
- 8.2 With the lawn mower drained of all fluids, follow the cleaning instructions as set out in section 7.62 to 7.72.
- 8.3 Follow the maintenance section and check, service or replace serviceable items if required.
- 8.4 Using a silicone spray grease, lightly coat the lawn mower blade to prevent possible rusting during storage.
- 8.5 Using a silicone spray grease, lightly grease all moving parts on the lawn mower.
- 8.6 Refill the engine with approx. 600ml of Semi Synthetic SAE15W40 engine oil.
- 8.7 Remove the spark plug and pour 1 teaspoon of fresh engine oil down the cylinder bore. Cover the spark plug hole with a lint free clean cloth, ensuring no dirt or debris falls into the cylinder chamber and gently pull the recoil starter handle to coat the cylinder bore with the fresh oil.
- 8.8 Refit the spark plug.

- 8.9 Store the lawn mower in a cool, dry place away from sources of ignition and varying changes in temperature.
- 8.10 Do not stack anything on top of the lawn mower.

9. TROUBLESHOOTING



CAUTION

Where necessary, all corrective actions should be carried out by suitably qualified persons.

Problem	Possible Cause	Possible Corrective Action
Engine does not start	OPC cable not adjusted correctly	Adjust OPC cable
	Fuel tank is empty	Fill fuel tank
	Stale fuel	Drain carburetor float bowl
	Air filter element is dirty	Clean or replace air filter
	Spark plug is loose	Tighten spark plug
	Spark plug cap loose or disconnected	Correctly fit the spark plug cap
Spark plug faulty	Spark plug gap is incorrect	Set plug gap to 0.7 – 0.8mm or Replace spark plug
	Carburetor is flooded with fuel	Remove the air filter and pull starter rope until carburetor clears
	Faulty ignition module	Contact the service dealer
Engine difficult to start or loses power	Dirt, water or stale fuel in tank	Drain fuel and clean tank Fill with clean, fresh fuel
	Vent hole in fuel tank is clogged	Clean or replace fuel tank cap
	Air filter element is dirty	Clean or replace air filter element
Engine operates erratically	Spark plug is defective	Fit new, correctly gapped spark plug
	Spark plug gap is incorrect	Set plug to 0.7 – 0.8mm
	Air filter element is dirty	Clean or replace air filter element
Engine idles poorly	Air filter element is dirty	Clean or replace air filter element
	Air slots in engine are blocked	Remove debris from slots
	Cooling fins and air passages under engine housing are blocked	Remove debris from cooling fins and passages
Engine skips at high speed	Spark plug electrode gap is incorrect	Set plug gap to 0.7 – 0.8mm
Engine Overheating	Cooling airflow is restricted	Remove any debris from slots in shroud, blower housing, air passages
	Incorrect spark plug	Fit new spark plug
Mower vibrates abnormally DO NOT use the machine until vibration issue has been fixed	Cutting assembly is loose	Tighten blade
	Blade/cutting assembly is unbalanced	Take to a service dealer

10. SPECIFICATION

	P4100P	P4600SP	P5100SPE
Engine Type	Hyundai OHV 4-Stroke		
Engine Size – cc	80	139	173
Fuel Tank Capacity - l	0.8	1.0	1.0
Fuel Type	Unleaded Petrol		
Oil Capacity – ml	600	600	600
Oil Type	Semi Synthetic SAE15W40		
Rated Speed - rpm	2800		
Rated Power – kW	1.8	3.6	4.2
Drive Type	Push	Self-Propelled	Self-Propelled
Start Method	Recoil	Recoil	Recoil/Electric
Height Adjustment	3	6	6
Cutting Height – mm	25 - 65	25 - 75	
Cutting Width – mm	400	460	510
Cut and Collect	Yes	Yes	Yes
Cut and Drop	No	No	Yes
Mulching	No	No	Yes
Catcher Type	Polyester	Polyester	Polyester/Plastic
Catcher Volume – l	40	60	60
Deck Material	Treated Steel		
Wheel Size Front – mm	150	180	200
Wheel Size Rear - mm	150	250	280
Handle Type	Soft Grip		
Noise Level - dB	96	96	96
Net Weight - Kg	21.5	33	37
Product Dimensions - mm	685 x 530 x 440	770 x 565 x 440	900 x 580 x 530

11. RECYCLING & PRODUCT DISPOSAL

- 9.0 We do not offer a takeback scheme for the recovery of Waste Electrical Electronic Equipment (WEEE) & Batteries.
Instead the responsibility to dispose of WEEE and or Batteries is passed onto you by us.
So when it becomes necessary to dispose of your machine you must take it to your local Civic Amenity Site.
For further information please contact your local Authority for disposal advice.
- 9.1 You **MUST** make sure that all unused oil and fuel is disposed of correctly either beforehand or at your local Civic Amenity Site.
Under NO circumstances must any fuel or oil be put down any drains.
- 9.2 Certain products contain WEEE waste which should not be disposed of in your domestic waste.
- 9.3 You **MUST** recycle WEEE in accordance with your local authority or recycling centre.
- 9.4 Certain products contain batteries which should not be disposed of in your domestic waste.
- 9.5 You **MUST** recycle batteries in accordance with your local authority or recycling centre.
- 9.6 Unwanted packaging and materials should be stored and taken to a recycling centre so it can be disposed of in a manner which is compatible with the environment.
- 9.7 The following symbol means that you should 'Reduce – Reuse – Recycle'.
- 9.8 We are a Member of the VALPAK National Compliance Scheme and our registration number is **RM08660**
- 9.9 For further information about disposal please contact your Local Authority.
- 9.10 You can also get more advice and guidance about recycling at the following website <http://www.recycle-more.co.uk>
- 9.11 Should you pass this product on to another user either sold or loaned, you **MUST** pass on this user manual.
This will make sure that all other users can use and maintain this machine safely.

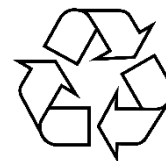
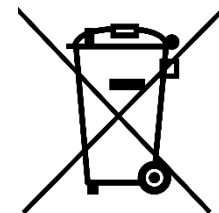

12. DECLARATION OF CONFORMITY

Genpower Ltd confirms that these Hyundai products conform to the following CE Directives.

2006/42/EC Machinery Directive

2004/108/EC EMC Directive

2000/14/EC, Amended by 2005/88/EC Noise Emissions Directive

97/68/EC_2010/26/EC NRMM Emissions Directive

EC DECLARATION OF CONFORMITY

The undersigned. As authorised by: **Genpower Ltd**
Declares that the following equipment manufactured under licence

Conforms to the Directive:-

2000/14/EC (as amended)

Of the European Parliament and of the council on the approximation of the laws of the Member States relating to the noise emission in the environment by equipment for the use outdoors.

Equipment Category: **Garden Machinery**

Product Name/Model: **P4100P
P4600SP
P5100SPE**

Type/Serial No: **Petrol Lawn Mower**

Net installed power: **P4100P 1.6kW
P4600SP 3.6kW
P5100SPE 4.2kW**

The technical documentation is kept by: **Roland Llewellyn, Genpower Ltd
Isaac Way, Pembroke Dock,
Pembrokeshire, SA72 4RW.**

The conformity assessment procedure followed was in accordance with annex V of the Directive.

Notified Body: **TüV Rheinland Luxemburg GmbH
2a Kalchesbruk
1852 Luxembourg.
Certification n° OR/027431/001**

Measured Sound Power Level: **P4100P 94dB
P4600SP 96dB
P5100SPE 96dB**

Guaranteed Sound Power Level: **P4100P 96dB
P4600SP 96dB
P5100SPE 96dB**

A copy of this certificate has been submitted to the European Commission and the EU Member State United Kingdom.

Place of Declaration: **Pembroke Dock, SA73 4RW**
Date: **07/03/2018**
Signed by: **Roland Llewellyn**



Position in Company: **Managing Director**

Name and address of manufacturer or Authorised representative:
**Genpower Ltd
Isaac Way, Pembroke Dock,
Pembrokeshire, SA72 4RW**

13. CONTACT DETAILS

10.0	POSTAL ADDRESS	Genpower Ltd, Isaac Way, London Road, Pembroke Dock, Pembrokeshire. SA72 4RW. United Kingdom
10.1	TELEPHONE	+44 (0) 1646 687 880
10.2	FAX	+44 (0) 1646 686 198
10.3	AFTER SALES	aftersales@genpower.co.uk
10.4	WEB ADDRESS	www.p1pe.co.uk

14. WARRANTY

- 11.0 To register your machine for the manufacturer's warranty, please visit
<https://www.p1pe.co.uk/warranty>

15. MANUAL UPDATES

- 12.0 Our manuals are constantly being reviewed and updated.
However if you find an error, omission or something you find unclear, please
contact your dealer for assistance.
- 12.1 Our latest manuals are also placed online.
- 12.2 We reserve the right to make any modifications without prior notice whenever
necessary.



**P1PE – Position One Power Equipment
Isaac Way, Pembroke Dock,
Pembrokeshire.
SA72 4RW**