



BELLE  
LIGHT  
CONSTRUCTION  
EQUIPMENT



Altrad-Belle.com

# DX 1000HT

## 1-TONNE, HI-TIP DUMPER

The DX 1000HT is the new No.1 Best in Class 1-tonne, high-tip dumper.

Designed to be owned by a rental company or professional operator. The DX 1000HT sets new standards for safety, strength, operator comfort and convenience and productivity on site.

With a proven, reliable Yanmar 3TNV76, 3 cylinder, Diesel engine....**perfect for this application!**



BUILDING A SUSTAINABLE FUTURE

# dX 1000ht 1-tonne hi-tip dumper

## A DIAMOND IN THE ROUGH!!

### FEATURES & BENEFITS

#### Operator Comfort and Convenience

- Fuel level is visible while in the operator's seat, saving time & improving safety & down time.
- Increased leg room for improved operator comfort.
- USB phone charger point, allowing charging while the work is done.
- Leading brand, comfort seat compliant to latest standards EN ISO 7096 for this type of equipment. Reduces operator fatigue, improves operator experience.

#### Strength

- Robust, easy-clean skip with fully returned edges preventing dirt ingress / concrete accumulation, reducing down time and cleaning costs.
- Strengthened chassis rails to increase durability.
- High quality, shot-blast and 2-layer powder coated paint finish for the most demanding site conditions. Maximising resale values.
- Bushed & greased steering pivot cylinder, preventing wear on the main components, cost efficient for the owners.
- Steel belly pan protector prevents damage to hydraulic circuit.
- Front enclosure / infill plate reduces stone / mud ingress meaning less down time & cleaning required.
- Steering Ram - Hose guard cover plate to prevent damage.
- Hi-quality leading brand all-terrain tyres fitted with valve protect guard, to reduce down time on site and increase productivity.



**HIGH-QUALITY, ALL-TERRAIN TYRES WITH VALVE PROTECT GUARD & WHEEL NUT INDICATORS**



**ROBUST, EASY-CLEAN 1000KG CAPACITY SKIP FULLY RETURNED EDGES TO PREVENT DIRT INGRESS**

## Productivity

- The Altrad full 4 wheel drive system hydraulic system gives increased traction on poor terrain and excessive mud. Better gradeability, increased productivity and less servicing.
- Reliable, Yanmar 3TNV76, water-cooled Diesel engine - perfect for this application.
- Market leading fuel tank capacity, reduces amount of fill-ups and down time.
- Unique fuel level indicator window together with a low fuel level warning light allows for easy inspection and assist in ensuring rental & machine productivity high.
- Low hydraulic fluid level warning light reducing system damage and down time.
- Extensive use of hose clamp retainers to prevent pipe fretting and rubbing, reducing hose failures and maintenance costs.
- Fuel and Hydraulic tank drain points reducing tank flushing time in the event of contamination or servicing.
- Fuel - water separator reducing engine damage and down time.
- Central Hydraulic hoses enables increased protection, reducing the risk of down time.
- Under footplate - stone guards preventing stone/mud ingress, so less down time & cleaning required.



## Safety

- Emergency Stop Button for increased safety.
- Tight turning circle allows better manoeuvrability on tight work sites, reducing shunting and increasing safety, productivity & efficiency.
- High viz access points & anti-slip foot-steps reduces slips, trips and falls when climbing on and off machine. Easily replaceable in case of an impact.
- Auto retracting seat belt prevents entanglement. Bright Orange for safety with increased visibility.
- Safe heavy duty, easy to deploy steering lock out bar, makes workshop and transport actives safer.
- "Check Point" visual wheel nut indicators make daily checks simpler to perform, reducing machine down time.
- Enclosed document box to retain machine safety documents reducing possibility of being damaged / misplaced.
- Lockable seat pan - gas strut c/w lock out reduces chance of head / trapping injuries.
- Anti-slip, hot-dipped galvanised floor plate for safety and long life.
- Hazard warning chevron's on rear of dumper for increased machine visibility on site to others.
- Priority / safety steering valve that gives priority to the steer function in the event of low hydraulic fluid pressure or flow, therefore maintain-highest levels of machine safety at all times.



**ROBUST STEEL, FRONT MATERIAL INGRESS GUARD PREVENTS DAMAGE TO HYDRAULIC CIRCUIT**



# BELLE LIGHT CONSTRUCTION EQUIPMENT

**EMERGENCY STOP BUTTON**  
Emergency Stop Button for increased safety

**USB PORT**  
USB phone charger point, allowing charging while the work is done

**HIGH QUALITY FINISH**  
High quality, shot-blast and 2-layer powder coated paint finish for the most demanding site conditions. Maximising resale values.

**ROBUST SKIP**  
Robust, easy-clean skip with fully returned edges preventing dirt ingress / concrete accumulation, reducing down time and cleaning costs.

**INGRESS GUARD**  
Robust steel, front material ingress guard prevents damage to hydraulic circuitry

**FULL 4-WHEEL DRIVE SYSTEM**  
The Altrad full 4 wheel drive system hydraulic system gives increased traction on poor terrain and excessive mud. Better gradeability, increased productivity and less servicing.

**HI-VIZ ACCESS POINTS**  
High viz access points reduces slips, trips and falls and off road incidents. Easily replaceable in



### COMFORT SEAT & OPERATOR STATION

Leading brand, comfort seat compliant to latest standards EN ISO 7096 for this type of equipment. Reduces operator fatigue, improves operator experience.

Operator station gives increased leg room for improved operator comfort.

### OPTION READY

Green Beacon, 2 x Worklights & 4 x Worklights options are available. Fully-loaded chassis harness and option-ready console means the options can be plugged-in and used immediately.

### FOLDING ROPS

Robust folding ROPS as standard for the highest safety and easy transportation.

### LOCKABLE SEAT PAN & GOOD SERVICE ACCESS

Lockable seat pan with locking gas strut reduces chance of head / trapping injuries. Gives good access to key service points for ease of servicing.

### YANMAR 3TNV76 DIESEL ENGINE

Reliable, Yanmar 3TNV76, water-cooled Diesel engine - perfect for this application and Market leading fuel tank capacity, reduces amount of fill-ups and down time

### HIGH QUALITY TYRES & WHEEL NUT INDICATORS

High quality, leading brand all-terrain tyres for excellent off-road performance with "Check Point" visual wheel nut indicators make daily checks simpler to perform, reducing machine down time.

### SAFETY POINTS

Handrails & anti-slip foot-steps reduce risk of falls when climbing on machine. In case of an impact.



## DX 1000HT 1-TONNE HI-TIP DUMPER

Part Number ..... DX10HYSA

### PERFORMANCE

Payload	(kg)	1000
Unladen Weight	(kg)	1363
Tipping Type		Front Tip - High
Turning Circle of Skip	(mm)	2637
Turning Circle of Tyres	(mm)	2524
Steering Angle	(°)	39.7
Body Oscillation Angle	(°)	15

### CAPACITIES

Skip - Water	(Ltr)	280
Skip - Struck	(Ltr)	400
Skip - Heaped	(Ltr)	500
Fuel Tank	(Ltr)	35
Hydraulic Oil Tank	(Ltr)	18

### ENGINE

Engine Model	.....	Yanmar 3TNV76
Type	.....	Diesel
No. of Cylinders	.....	3
Gross Power	(Hp/kW)	21.4 / 15.9
Displacement cc	(cc)	1116
Max. Torque	(Nm)	66.4

### HYDRAULIC SYSTEM

Pump Type	.....	Gear Pump
Flow Rate	(l/min)	30
Operating Pressure	(bar/PSI)	140
Steering System	.....	Hydraulic

### BRAKING SYSTEM

Working Brake	...	Hydrostatic Dynamic Breaking
Parking Brake	.....	Failsafe Automatic



**GOOD ACCESS TO KEY FEATURES WITH SELF-LOCKING GAS STRUT AND PROVEN YANMAR 3TNV76 DIESEL ENGINE**

### TRANSMISSION / DRIVE

Transmission Type	.....	Hydrostatic Pump to 4 radial piston Hydraulic Motors
Tyre Size	.....	255 / 75 -15.3
Drive	.....	Hydrostatic
Max. Travel Speed (Unladen)	(kph)	12
Max. Gradient	.....	25% (4:1)

### ENVIRONMENTAL

- Sound Pressure	(LpAd)	84
Sound Power Level	(LWAd)	101
Noise Emission (to ISO 4871)		

### ELECTRICAL SYSTEM

System Voltage	(V)	12
Battery Capacity	(Ah)	44
Alternator Output	(A)	40

### STANDARD EQUIPMENT

Folding ROPS Frame	✓
Reversing Alarm	✓
Flashing Orange Beacon	✓
Hourmeter	✓
Seat Belt (Hi-Viz Orange)	✓
Adjustable Seat	✓
Heavy Duty Articulation Lock	✓
Wide Tyres	✓



**ERGONOMIC OPERATOR STATION WITH EASY-TO-REACH CONTROLS, LEADING BRAND COMFORT SEAT AND GOOD ALL-ROUND VISIBILITY**

## STATIC DIMENSIONS\*

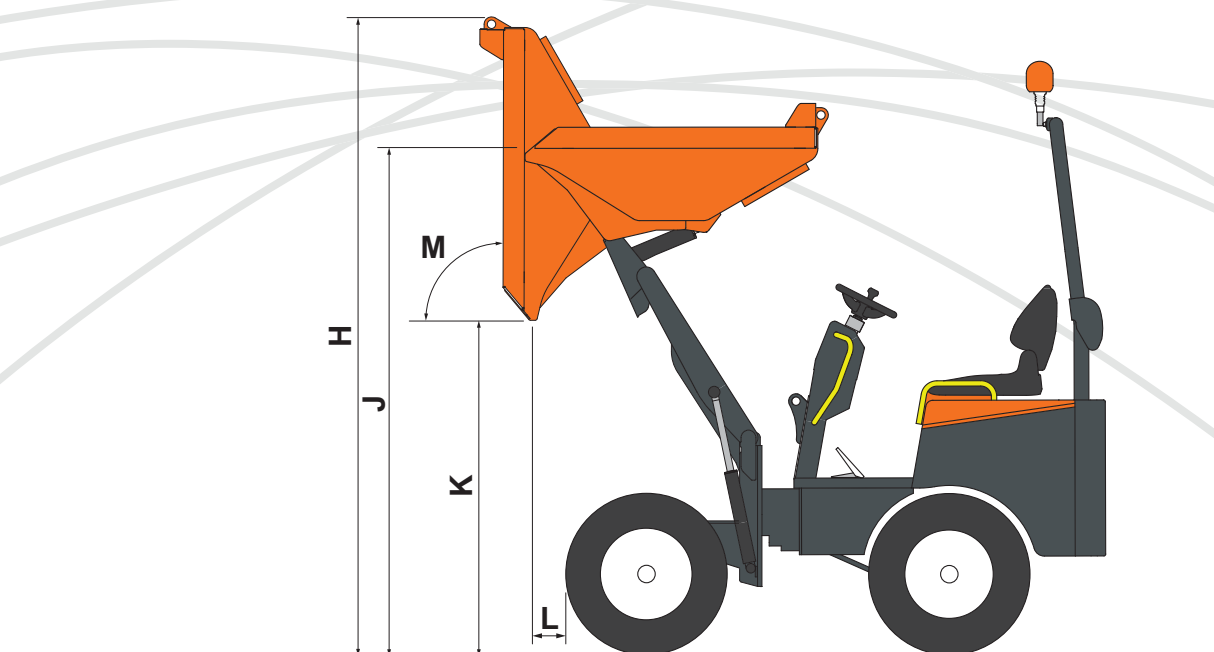
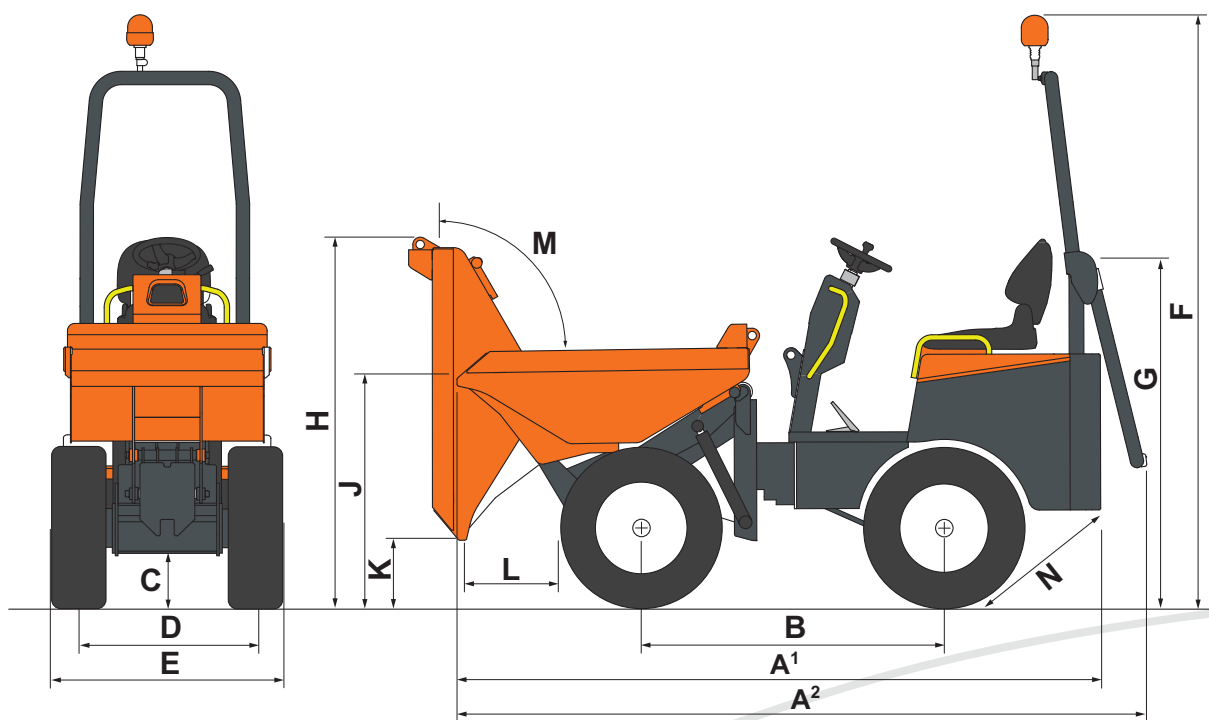

		Standard Wheels	cw Wheel Spacers
<b>A<sup>1</sup></b> - Overall Length	(mm)	3165	3165
<b>A<sup>2</sup></b> - Overall Length (ROPS folded)	(mm)	3330	3330
<b>B</b> - Wheel base	(mm)	1440	1440
<b>C</b> - Minimum ground clearance	(mm)	250	250
<b>D</b> - Track width	(mm)	850	950
<b>E</b> - Width over tyres	(mm)	1100	1200
<b>F</b> - Height to top of ROPS (raised, with/without beacons)	(mm)	2545 / 2800	2545 / 2800
<b>G</b> - Height to top of ROPS (folded)	(mm)	1630	1630
<b>H</b> - Dump Height (untipped/tipped)	(mm)	1820 / 2960	1820 / 2960
<b>J</b> - Height to front lip of dumper body (untipped, lowered/raised)	(mm)	1110 / 2270	1110 / 2270
<b>K</b> - Height to front lip of dumper body (tipped, lowered/raised)	(mm)	400 / 1540	400 / 1540
<b>L</b> - Discharge distance front (lowered/raised)	(mm)	520 / 380	520 / 380
<b>M</b> - Dumper body tip angle	(°)	81	81
<b>N</b> - Departure angle	(°)	38	38

# OPTIONS

## Option Ready

- Green Beacon ready - fitted with seat belt sensor & main harness is ready to take Green Beacon option.
- Twin Beacon and work light approved ROPS structure.
- Fully loaded chassis harness - ready for options to be plugged in and used.
- Option ready console - ready for options to be plugged in and used.
- Customer colour options giving excellent brand awareness.

## Options Available

- Work Lights x 2 OPD/20/DIO
- Work Lights x 4 OPD/21/DIO
- Green Beacon OPD/22/DIO
- Tow Hitch OPD/24/DIO
- UK Road Kit OPD/25/DIO
- 50mm Wheel Spacers x 4 OPD/28/DIO
- White Noise Back-Up Alarm OPD/29/DIO
- Site Anti-Tamper Kit OPD/30/DIO

## Worklights

- Available as a kit of 2 worklights or 4 worklights.
- Super bright 54W work light with 9 x 6W LED's, producing 4500 Lumens.
- Lightweight Aluminium Housing with stainless steel adjustable bracket.
- Protected to IP69K.
- Simple to fit / remove.



2X & 4X WORK LIGHT OPTIONS AVAILABLE

## Green Beacon

- Tough, leading brand quality 9W beacon with 40 LED's.
- Simple to fit / remove.
- Lockable under-canopy storage for both the Green & Orange beacons.
- Flexible mounting to reduce damage.



LOCKABLE UNDER-CANOPY BEACON STORAGE

## Tow Hitch

- Ideal for moving trailers, caravans etc. around site.
- 750kg maximum towing weight on flat ground (including the weight of the towed equipment).
- Combination hitch - 50mm Ball & Jaw/Pin.
- Adjustable height for correct towing position.
- Simple to fit / remove.



TOW HITCH OPTION



## OPTIONS

### UK Road Kit

- Kit includes headlights, brake lights, front & rear facing indicators, number plate mount (c/w number plate light and the following console switches/displays:-
  - Side Lights Switch
  - Road Lights Switch
  - Indicators Switch
  - Hazard Lights Switch
  - Display Indicator
- Accepts 279mm x 203mm standard, rear facing number plate
- 60/55W Headlights are enclosed in a durable steel mesh cage and mounted on a robust bumper bar for added protection.
- Red, White & Amber reflectors for increased visibility in poor light conditions.
- Simple to fit / remove.
- Designed to comply with BS ISO 12509:2004

### Wheel Spacers

- Increases the track width of the machine by 100mm giving added safety and stability in both static and dynamic conditions.
- Locking nuts for additional safety.
- Removeable for tight-access jobsites.
- Compatible with existing machines
- Corrosion resistant protective coating.
- Simple to fit / remove.



**BRAKE LIGHTS, INDICATORS & NUMBER PLATE MOUNT FROM UK ROAD KIT OPTION**



**HEAD LIGHTS & INDICATORS FROM UK ROAD KIT OPTION**



**WHEEL SPACER OPTION ADDS 100MM TO THE TRACK WIDTH GIVING ADDED SAFETY & STABILITY**



**ALTRAD BELLE**  
Sheen, Nr. Buxton, Derbyshire, SK17 0EU, GB  
Tel. +44 (0)1298 84606 - Fax +44 (0)1298 84722  
Email: [sales@altrad-belle.com](mailto:sales@altrad-belle.com)  
[www.Altrad-Belle.com](http://www.Altrad-Belle.com)  
[www.Altrad-Belle247.com](http://www.Altrad-Belle247.com)

